

A42M

PHOTOELECTRIC ROTARY ENCODER



Photoelectric modular rotary encoder A42M is of incremental type and provides up to 25.000 output pulses per revolution. The absence of

bearings and lubricants makes the encoder suitable for use in vacuum environment or situations when zero starting torque is required.

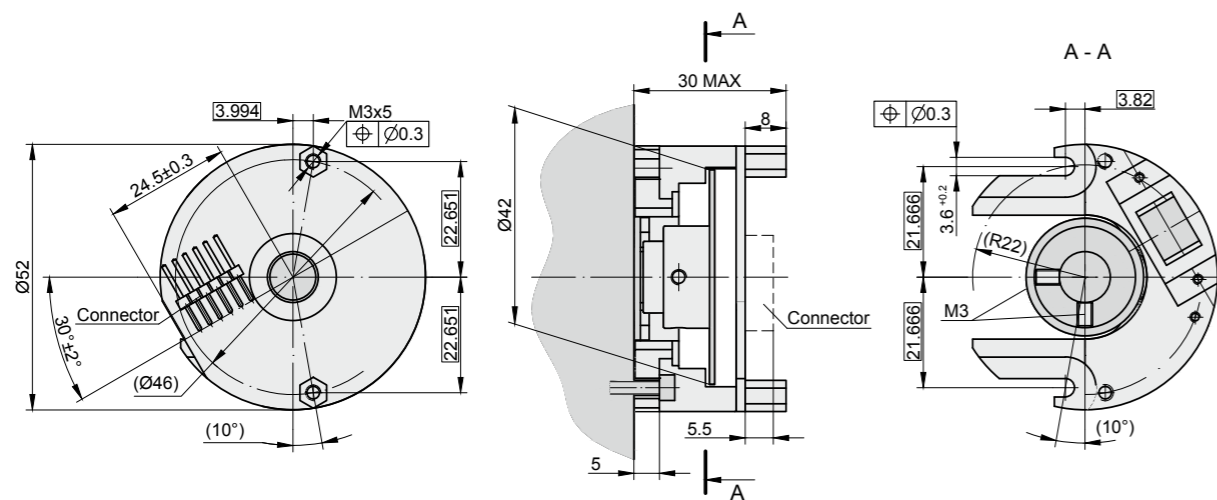

MECHANICAL DATA

Line number on disc (z)	1000, 2500 (others on request)	Protection (IEC 529)	IP00
Number of output pulses per revolution for A42M-F	Z x k, where k=1,2,5,10	Max. weight: - rotor assembly - scanning unit	0.022 kg 0.04 kg
Max. permissible mechanical rotation speed	20000 rpm	Operating temperature	-10...+70 °C
Accuracy (T ₁ period of lines on disc in arc. sec.)	±0.1T ₁ arc. sec.	Storage temperature	-30...+85 °C
Permissible axial shaft run out	0.05 mm	Maximum humidity (non-condensing)	98 %
Hub inside diameter	10, 8, 6 mm	Permissible vibration (55 to 2000 Hz)	≤ 100 m/s ²
Rotor moment of inertia	< 22 gcm ²	Permissible shock (6 ms)	≤ 1000 m/s ²

ACCESSORIES

CONNECTORS FOR CABLE	B12 12-pin round connector	C9 9-pin round connector	C12 12-pin round connector	D9 9-pin flat connector	D15 15-pin flat connector	RS10 10-pin round connector	ONC 10-pin round connector
CONNECTOR FOR PCB	Adapter Cable dia. 7 mm with PCB connector						
DIGITAL READOUT DEVICES	CS3000			CS5500			
EXTERNAL INTERPOLATOR	NK						

ELECTRICAL DATA

VERSION	A42M-A \sim 11 μ App	A42M-AV \sim 1Vpp	A42M-F \square TTL
Power supply	+5 V \pm 5% / < 80 mA	+5 V \pm 5% / < 120 mA	+5 V \pm 5% / < 120 mA
Light source	LED	LED	LED
Incremental signals	Two sinusoidal I ₁ and I ₂ Amplitude at 1 k Ω load: - I ₁ = 7-16 μ A - I ₂ = 7-16 μ A	Differential sine +A/-A and +B/-B Amplitude at 120 Ω load: - A = 0.6-1.2 V - B = 0.6-1.2 V	Differential square-wave U1/U1 and U2/U2. Signal levels at 20 mA load current: - low (logic "0") < 0.5 V - high (logic "1") > 2.4 V
Reference signal	One quasi-triangular I ₀ peak per revolution. Signal magnitude 1 k Ω load: - I ₀ = 2-8 μ A (usable)	One quasi-triangular +R and its complementary -R per revolution. Signals magnitude at 120 Ω load: - R = 0.2-0.8 V (usable)	One differential square-wave U0/U0 per revolution. Signal levels at 20 mA load current: - low (logic "0") < 0.5 V - high (logic "1") > 2.4 V
Maximum operating frequency	(-3 dB) \geq 160 kHz	(-3 dB) \geq 180 kHz	(160 x k) kHz, k-interpolation factor
Direction of signals	I ₂ lags I ₁ for clockwise rotation (viewed from shaft side)	+B lags +A for clockwise rotation (viewed from shaft side)	U2 lags U1 with clockwise rotation (viewed from shaft side)
Maximum rise and fall time	-	-	< 0.5 μ s
Recommended max. cable length to subsequent electronics	5 m	25 m	25 m
Output signals			

Note:

- Maximum working rotation speed (with proper encoder counting) is limited by maximum operating frequency and maximum mechanical rotation speed.
- If cable extension is used, power supply conductor cross-section should not be smaller than 0.5 mm².

MOUNTING DIMENSIONS

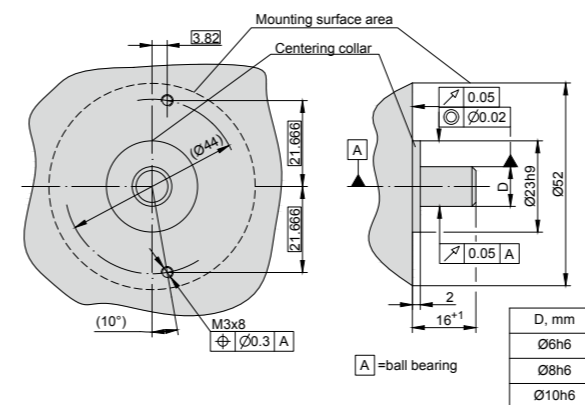

PCB CONNECTOR

AC
Adapter Cable dia.
7 mm with PCB connector



ORDER FORM

A42M - X - XXXX/XXXX - XX - XXXX / X

OUTPUT SIGNAL VERSION:	PULSE NUMBER PER REVOLUTION:	(OPTIONAL) LINE NUMBER ON DISC (Z):	HUB INSIDE DIAMETER:	ADAPTER CABLE:	CONNECTOR TYPE FOR ADAPTER CABLE:
A AV F	1...1000 ... 1...25000	1000 2500 *only for A42M-F	06 - \varnothing 6mm 08 - \varnothing 8mm 10 - \varnothing 10mm	W - without cable AC01 - 1m AC02 - 2m AC03 - 3m ...	W - without connector B12 - round, 12 pins C9 - round, 9 pins C12 - round, 12 pins D9 - flat, 9 pins D15 - flat, 15 pins RS10 - round, 10 pins ONC - round, 10 pins
ORDER EXAMPLES:	1) A42M-AV-2500-10-AC01/W 2) A42M-F-5000-06-W/W 3) A42M-F-5000/1000-06-W/W				